



CATALOGUE PRODUCTS 2025

HOT WATER R290 | MONOBLOC R290 | HEATERS ONSEN
ONLY IN | TOTAL HEAT EXCHANGER



Termal



ECO-FRIENDLY PRODUCTS FOR SMART AIR CONDITIONING

Termal is a leading company in the marketing of plant equipment for domestic use.

It offers a range of R290 products in heat pumps and water heaters for heating and DHW production, as well as air conditioners suitable for historic centers, units for heating swimming pools and for air treatment.

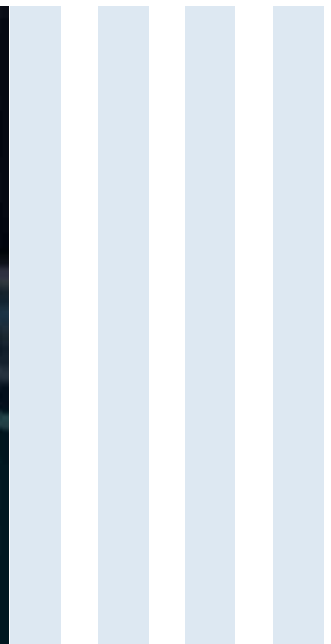

| | |
|-------------------------------|----|
| LINE UP PRODUCTS | 3 |
| ■ HOT WATER R290 | 4 |
| APPLICATIONS | 8 |
| DATA SHEETS | 12 |
| ■ MONOBLOC R290 | 16 |
| DATA SHEETS | 18 |
| ■ ONSEN HEATERS | 20 |
| DATA SHEETS | 22 |
| ■ ONLY IN | 26 |
| DATA SHEETS | 29 |
| ■ TOTAL HEAT EXCHANGER | 30 |
| DATA SHEETS | 31 |





Line up

A RANGE COMPLETE AND ADVANCED

WATER HEATER HOT WATER



DUCTED Kitchen

80/100/150L
monobloc tank
TWMMS 09080 J
TWMMS 09100 J
TWMMS 09150 J

GAS R290



DUCTED

200/300/400L
monobloc tank
TWMMS 2203 J-1
TWMMS 2303 J-1
TWMMS 2403 J-1

GAS R290

MONOBLOC

Monobloc heat pump with R290 for high temperature DHW production only (up to 70°C with compressor only).

GAS R290



TWMMS 9000 J

TWMMS 16000 J

ONSEN SWIMMING POOL HEATERS



TCPHNB 1201 Z
TCPHNB 1501 Z
TCPHSB 3101 Z



GAS R32

TCPVSB 4001 Z
TCPVSB 4601 Z

AIR CONDITIONER WITHOUT OUTDOOR UNIT

Cool in the summer. Warm in the winter.
Design all year long.

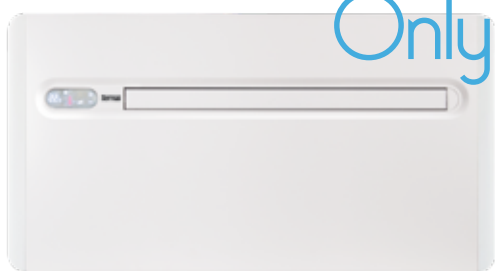

Only in

TTWIS 310 Z
GAS R32

TOTAL HEAT EXCHANGER

Recovering energy during air exchange in environments.



ETIN 805-2005

HEAT PUMP WATER HEATERS HOT WATER

DOMESTIC
HOT WATER
UP TO 70°C





Eco-friendly R290 refrigerant

R290 refrigerant gas is a natural hydrocarbon, also known as propane, widely used as a refrigerant in air conditioning systems and heat pumps.

Among its main advantages are energy efficiency, low environmental impact (GWP=0.02) and adherence to ecological standards, all elements that contribute to the sustainability of the installed system. Its high thermal efficiency makes it an eco-friendly choice for heating systems and DHW production.

A complete range for any application

Efficiency - Savings - Well-being

The Termal Hot Water range of heat pump water heaters is characterised by a large number of solutions capable of satisfying any need in a range of applications, both on a small and large scale. Termal technology solutions include products:

- Ducted Kitchen
- Ducted

With the use of the compressor alone, the Ducted and Ducted Kitchen models at R290 can bring the water up to 65° C. All models can bring the water to a maximum of 70° C via the electrical resistance.

At such temperatures, it is possible to perform periodic thermal disinfection cycles of the stored hot water, which can prevent the proliferation of Legionella bacteria.

All solutions are **ideal for new buildings and renovation projects**.

Advantages

All DUCTED models are equipped with a **titanium anode** that permanently protects the tank from the corrosive effects of water.

As opposed to a magnesium anode solution, the service life of the tank is extended and little maintenance is required, thus reducing the costs of periodic servicing.

Like any metal structure in direct contact with an electrolyte (water), the heating elements are also subject to the phenomenon of corrosion. Electrochemical reactions cause decomposition and re-composition with other elements of the metals from which they are made, inevitably compromising their structure.

The Titanium Anode is an **environmentally friendly solution** which is “clean” and designed and engineered to operate using as little energy as possible.

The anode is electrically powered by means of a direct current that is circulated between the device and the tank to be protected.

At the heart of the system is the innovative electronics completely managed by a state-of-the-art microprocessor **capable of achieving performance hitherto unthinkable for this specific application.**

The regulation of the impressed current value is based on a highly efficient calculation algorithm, which allows the control of the correct current intensity in accordance with the instantaneous degree of protection and the reaction time of the tank.

The reading of the system's potential value through the same titanium electrode takes place in dynamic mode, allowing the current flow to be maintained once the equilibrium value is reached, without frequent interruptions or even partial variations in intensity.

The ability of Titanium Anode to self-learn and adjust to the actual conditions of the structure under protection, **means that even the delivery of the impressed current is dynamic and perfectly balanced to the needs of the system to be protected.**





Ducted Kitchen series

The “Ducted Kitchen” series is designed to be installed inside the tall cabinetry of the kitchen. The range consists of three tank sizes (80/100/150L) with external air expulsion and both internal and external intake.

Thanks to the wall-mounted installation, it is possible to further optimize the spaces inside the technical compartment.



Ducted series

To be positioned indoors, it can be used in different installation configurations, with or without air intake or expulsion ducting. Thanks to the possibility of parallel or series installation (centralised systems), Termal Hot Water in the “Ducted” series is also suitable for large-volume hot water requirements.

Versatile installation allows the full energy of the air to be harnessed

Air intake and/or expulsion is possible in the installation premises or with air intake and/or expulsion ducts from other premises. A condensate drainage network must be created.

In particular, the “Ducted” series allows the heat pump system to be used in **5 installation modes**:

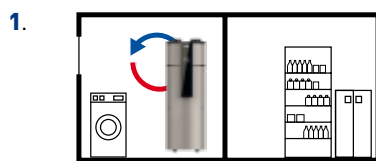

Recirculated air installation: air inlet and outlet take place in the installation premises. DHW is produced by exploiting the air in the room and at the same time removing heat and humidity from it, cooling it. The installation of a partition to prevent air recirculation in the immediate vicinity of the extraction vent is recommended.

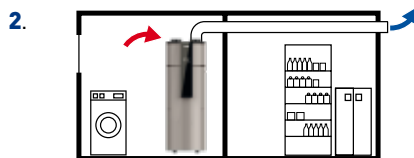

Installation with internal air intake: with air extraction outdoors. DHW is produced by exploiting the air in the installation premises, which is then expelled outside via ducting.

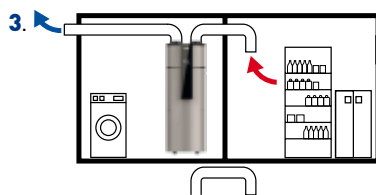

Installation with air intake from another room and expulsion to the outside via ducting. In situations where there are rooms with a high degree of heat build-up, this installation mode allows the system to work with a high level of energy efficiency, guaranteeing the exchange of air without the need to open the window.

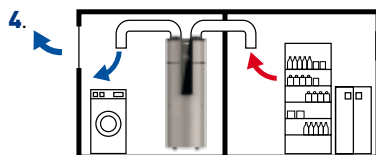

Installation with air intake from another room and expulsion inwards (with or without ducting in rooms with openings to the outside). An advantageous situation for example in cellars where cold, dehumidified air is needed.

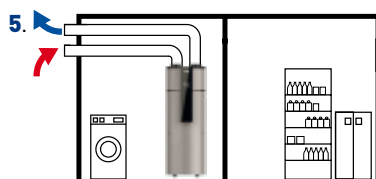

Installation with air intake and extraction to the external environment. This mode ensures that there is no variation in the temperature of the room where the Hot Water is installed. Operation depends on the minimum and maximum temperature of the external air intake (see product data sheets). This application is mainly used in locations with mild temperatures.

EXAMPLES OF RESIDENTIAL AND COMMERCIAL APPLICATIONS

Termal models are made of innovative materials to ensure a long service life. Furthermore, they are quiet and efficient.

The various power ratings meet all energy needs, and the availability of hot water will no longer be a problem.



| | |
|----------------------------------|----|
| ■ Independent homes | 9 |
| ■ Gyms or company changing rooms | 11 |

DHW with 80/100/150 L Hot Water **Ducted Kitchen** units in **R290** for independent homes

Description of the installation

The application type, illustrated in the figure, describes the installation in an apartment, which is newly built, being renovated or involves the replacement of existing installations.

Domestic hot water is produced by a single 80, 100 or 150 litres Hot Water unit.

The heat pump is designed to be installed in the kitchen, just like a traditional boiler, and is conveniently placed inside the tall cabinetry of the kitchen, with air extraction to the outside.

The "Ducted kitchen" series allows use in **2 installation modes**:

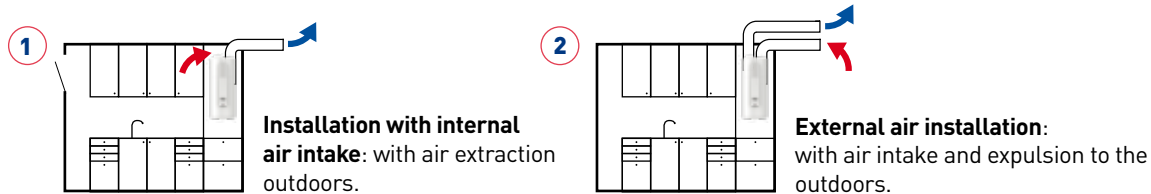

TWMS 09080 J
TWMS 09100 J
TWMS 09150 J
80/100/150 litres



 1
apartment

 1
bathrooms with
showers and
toilets

 1
family of 1/2
persons

 80/100/150 L
depending on the household's DHW use

Examples of residential applications

DHW with 200/300 L Hot Water **Ducted** units in **R290** for independent homes

Description of the installation

The application type, illustrated in the figure, describes the installation in an independent home, which is newly built, being renovated or involves the replacement of existing installations.

The production of domestic hot water is provided by one 200 or 300-litre monobloc Hot Water system.

The heat pump can be located in a technical or service room of the building, e.g. cellar or garage.

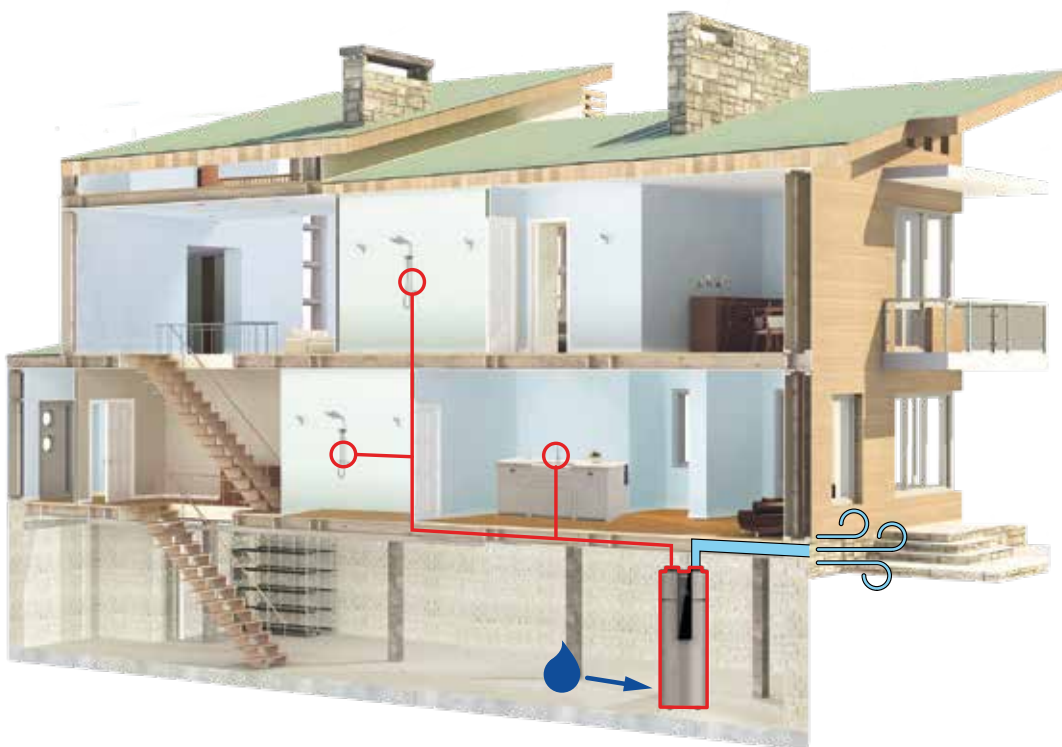

TWMB5 2203-2303 J-1
200/300 litres



apartment



bathrooms with
showers and
toilets



family of 3/4
persons



200/300 L

tank size

DHW with 300 L Hot Water **Ducted** units in **R290** for gyms or company changing rooms

Description of the installation

The application type, illustrated in the figure, describes the system in a company with a warehouse and offices.

The production of domestic hot water is provided by one 300-litre monobloc Hot Water system.

The heat pump can be located in a technical or service room, e.g. a central heating room, with ducting of the treated air.

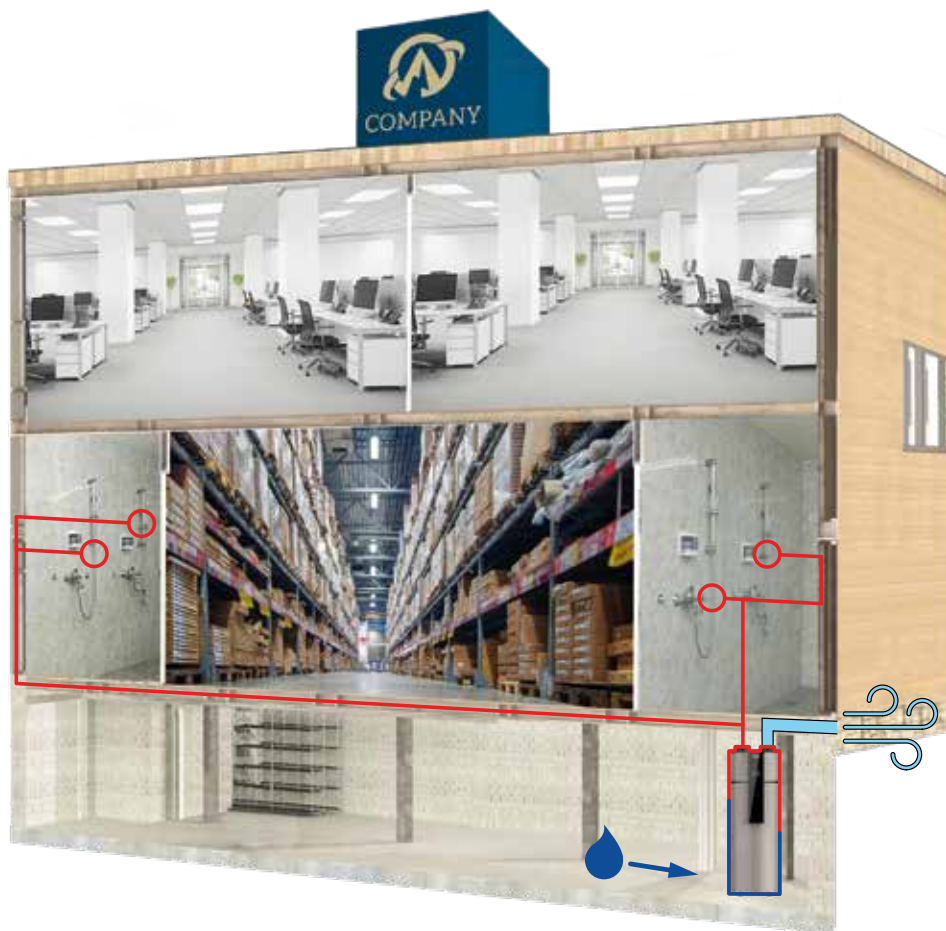

TWMB5 2303 J-1
300 litres



changing rooms (with 3 showers each)



users (5 per shift)



requirements per person



DHW requirements per day



water supply temperature to utilities

Hot Water monobloc 80/100/150 litres at **R290** **Ducted Kitchen** series

INTEGRATED
Wi-Fi 



TWMMMS 09080 J
TWMMMS 09100 J
TWMMMS 09150 J

- Monobloc heat pump water heater, designed to be installed inside the tall cabinetry of the kitchen
- R290 refrigerant gas
- Vitrified galvanized steel
- Energy Efficiency Class **A+**
- Hot water up to 65° C with compressor only
- Anti-Legionella cycle
- Exceptional resistance to corrosion thanks to the **titanium anode included as standard**

Energy class



| Model | | TWMMMS 09080 J | TWMMMS 09100 J | TWMMMS 09150 J | |
|---|---|--------------------|----------------------------|--------------------|--------------|
| Tank volume | L | 78 | 98 | 145 | |
| Rated thermal power ¹ | W | 950 | 980 | 1300 | |
| Rated power consumption ¹ | W | 250 | 258 | 351 | |
| COP (rated) ¹ | W/W | 3.80 | 3.80 | 3.70 | |
| Rated hot water production capacity ¹ | L/h | 20.5 | 21.0 | 28.0 | |
| COPDHW ² | W/W | 2.61 | 2.61 | 2.79 | |
| Test cycle profile ² | - | M | M | L | |
| Hot water volume at 40°C ² | L | 85 | 110 | 160 | |
| Energy efficiency (η _{wh}) ³ | % | 112 | 111 | 122 | |
| Energy Efficiency Class ³ | - | A+ | A+ | A+ | |
| IP protection rating | - | IP21 | IP21 | IP21 | |
| Hot water T. adjustment range | °C | 38~70 (50 default) | 38~70 (50 default) | 38~70 (50 default) | |
| Maximum hot water T. compressor only | °C | 65 | 65 | 65 | |
| Electrical data | Power | Ph-V-Hz | 1-220~240V-50Hz | | |
| | Integrative heating element | W | 1500 | | |
| | Maximum current (including heating element) | A | 9.00 | 9.00 | 10.50 |
| Refrigerant circuit | Refrigerant ⁴ | type (GWP) | R290 (0.02) | | |
| | Quantity | kg | 0.15 | 0.15 | 0.15 |
| | Compressor | type | Rotary ON/OFF | | |
| Product specifications | Dimensions (D x H) | mm | ø500 x 1196 | ø500 x 1360 | ø500 x 1707 |
| | Net weight | kg | 57 | 62 | 80 |
| | Noise power level (without channels) | dB(A) | 54 | 54 | 56 |
| | Working range (compressor only) | °C | -7~+43 | | |
| Tank | Tank material | - | Vitrified galvanized steel | | |
| | Heat exchanger | type | Microchannel aluminum | | |
| | DHW hydraulic connections | inches | G1/2" (DN15) | G1/2" (DN15) | G1/2" (DN15) |
| | Titanium anode | - | Titanium electrode | | |
| | Maximum operating pressure | Mpa | 0.8 | 0.8 | 0.8 |
| Air ducts | Air flow (without ducts) | m ³ /h | 190 | 200 | 240 |
| | Fan static pressure (max) | Pa | 20 | 20 | 30 |
| | Air duct - Diameter | mm | 160 | 160 | 160 |
| | Air duct - Length | m | 5 | 5 | 5 |

1. Conditions: intake air 15°C DB (12°C WB), water inlet 15°C / outlet 45°C. 2. Test according to EN16147/2017; intake air 7°C, water inlet 10°C.

3. Directive 2009/125/EC - ERP EU No. 814/2013. 4. Refrigerant leakage contributes to climate change. When released into the atmosphere, refrigerants with a lower global warming potential (GWP) contribute less to global warming than those with a higher GWP. This appliance contains a refrigerant with a GWP of 0.02, if 1 kg of this refrigerant fluid were released into the atmosphere, therefore, the impact on global warming would be 50 times less than 1 kg of CO₂, over a period of 100 years. Under no circumstances should the user try to intervene on the refrigerant circuit or disassemble the product. Always contact qualified personnel if necessary.



Comfort at home

Designed to be installed in the kitchen, just like a traditional boiler, the "Ducted Kitchen" series is conveniently placed inside the tall cabinetry of the kitchen, with air extraction to the outside.

Safety

- The tank is protected from corrosion by the titanium anode included as standard.
- Anti-legionella system: the danger of legionella bacteria is averted thanks to periodic cycles that raise the temperature of the water inside the storage tank above 65°C.

Installation warnings

1. It is mandatory to install a safety and non-return valve on the cold-water inlet. Failure to do so could seriously damage the equipment. Use a valve with a 0.7 MPa setting. For the installation location, please refer to the piping connection diagram.
2. The discharge pipe of the safety valve must descend vertically and must not be placed in an environment where there is a risk of freezing.
3. The water must be able to drip freely from the pipe and its end must be left free.
4. The safety valve must be tested regularly to check its function and to remove any limescale that might block it.



Hot Water monobloc 200/300/400 litres at **R290 Ducted** series

INTEGRATED
Wi-Fi



- Floor-standing heat pump water heaters
- R290 refrigerant gas
- Titanium anode with alarm LED
- Additional 1.5 kW electric heating element
- Hot water up to 60°C with compressor alone; up to 70° C with electric heating element integration



TWMMBS 2203 J-1
TWMMBS 2303 J-1
TWMMBS 2403 J-1

Energy class



| Model | | TWMMBS 2203 J-1 | TWMMBS 2303 J-1 | TWMMBS 2403 J-1 |
|---|---|-------------------|-----------------------------------|-----------------|
| Tank volume | L | 200 | 300 | 400 |
| Rated thermal power ¹ | W | 1500 | 1500 | 1500 |
| Rated power consumption ¹ | W | 388 | 388 | 388 |
| COP (rated) ¹ | W/W | 3.87 | 3.87 | 3.87 |
| Rated hot water production capacity ¹ | L/h | 32.0 | 32.0 | 32.0 |
| COPDHW ² | W/W | 3.04 | 3.24 | 3.44 |
| Test cycle profile ² | - | L | XL | XXL |
| Hot water volume at 40°C ² | L | 291 | 377 | 479 |
| Energy efficiency (η _{wh}) ³ | % | 130 | 132 | 141 |
| Energy Efficiency Class ³ | - | A+ | A+ | A+ |
| IP protection rating | - | IPX1 | IPX1 | IPX1 |
| Hot water T. adjustment range | °C | 35~65 | 35~65 | 35~65 |
| Maximum hot water T. compressor only | °C | 65 | 65 | 65 |
| Electrical data | Power | Ph-V-Hz | 1-220~240V-50Hz | |
| | Integrative heating element | W | 1500 | 1500 |
| | Maximum current (including heating element) | A | 9.5 | 9.5 |
| Refrigerant circuit | Refrigerant ⁴ | type (GWP) | R290 (0.02) | |
| | Quantity | kg | 0.15 | 0.15 |
| | Compressor | type | Rotary ON/OFF | |
| Hydraulic data | Tank material | - | Stainless steel 304 | |
| | DHW hydraulic connections | inches | G3/4" (DN20) | |
| | Hydraulic solar coil connections | inches | - | - |
| | Maximum operating pressure | bar | 10 | 10 |
| Air ducts | Air flow (without ducts) | m ³ /h | 290 | 290 |
| | Fan static pressure (max) | Pa | 60 | 60 |
| | Inside diameter | mm | 180 | 180 |
| | Length Max | m | 8 | 8 |
| Product specifications | Operating range | °C | -5~-+43 | -5~-+43 |
| | Titanium anode | - | Titanium electrode with alarm LED | |
| | Sound power level | dB(A) | 51 | 51 |
| | Dimensions (D x H) | mm | ø560x1745 | ø640x1840 |
| | Net weight | kg | 80 | 85 |
| Controls | Wired control on board the machine | - | Included | |
| | WiFi Module | - | Integrated | |

1. Conditions: intake air 20°C DB (15°C WB), inlet water 15°C / outlet 55°C. 2. Test according to EN16147; air 7°C inlet water 10°C.

3. Directive 2009/125/EC - ERP EU n. 814/2013 (SGS-CSTC certification for all models). 4. Refrigerant leakage contributes to climate change. When released into the atmosphere, refrigerants with a lower global warming potential (GWP) contribute less to global warming than those with a higher GWP. This appliance contains a refrigerant with a GWP of 0.02. If 1 kg of this refrigerant fluid were released into the atmosphere, therefore, the impact on global warming would be 50 times less than 1 kg of CO₂ over a period of 100 years. Under no circumstances should the user try to intervene on the refrigerant circuit or disassemble the product. Always contact qualified personnel if necessary.

Hot Water

Product benefits

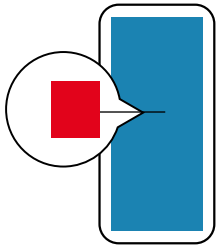

Durable titanium anode

Titanium anode as standard with the Hot Water system.



Comfort at home

- Programming to take advantage of any advantageous time slots on the electricity tariff and have hot water available when needed.
- Two operating modes: maximum savings with the use of the compressor alone or maximum speed with the simultaneous use of the heat pump and integrated electric heating element, to produce large quantities of DHW in a short time.

Safety

- Since the heat exchanger is outside the tank, no contamination between water and coolant is possible.
- Anti-legionella system: the danger of legionella bacteria is averted thanks to periodic cycles that raise the temperature of the water inside the storage tank above 65°C.
- The titanium anode permanently protects the tank from the corrosive action of the water, ensuring greater reliability and lower maintenance costs than a magnesium anode solution.

5 installation modes

1. Recirculated air installation: air inlet and outlet take place in the installation premises.
2. Installation with internal air intake and air extraction outdoors.
3. Installation with intake from another room and expulsion outdoors
4. Installation with air intake from another room and expulsion to an internal room (with or without ducting).
5. Installation with air intake and extraction to the external environment.

Hydraulic connections diagram

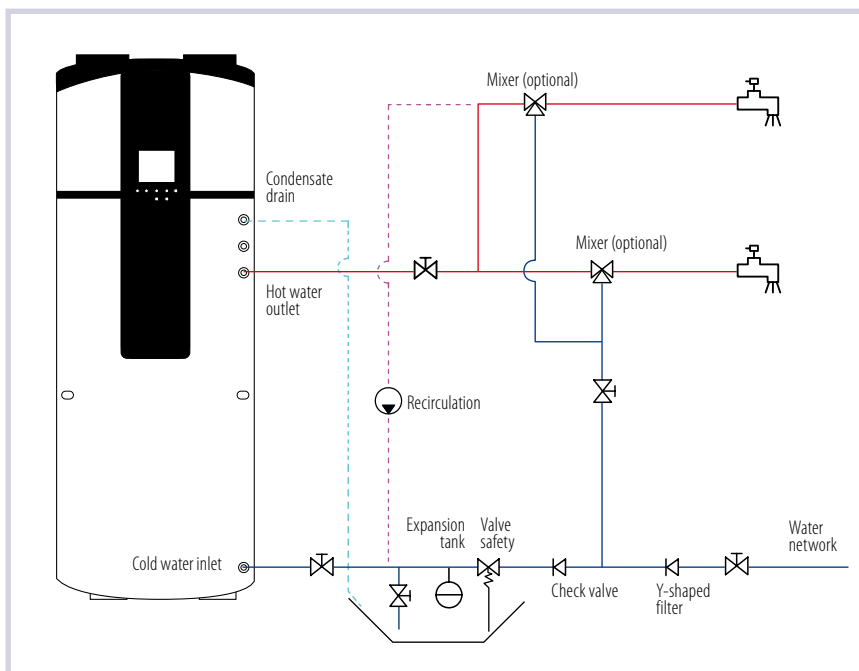

HEAT PUMP AIR-WATER MONOBLOC FOR DHW

WATER DELIVERY
TEMPERATURE UP TO 70° C
WITH COMPRESSOR ONLY





New Monobloc for DHW production only in **R290**

The Termal monobloc is the new innovative R290 heat pump, environmentally friendly and ready for the technological changes of the future.

It offers maximum energy efficiency and is perfect both for meeting the requirements for new buildings and for use in renovations thanks to the delivery temperature of 70°C achieved with the compressor alone.

Installation must take place scrupulously following current regulations.

Monobloc for DHW production only in R290

- DHW up to 70° C compressor only
- Refrigerant gas R290
- Circulation pump included
- Expansion vessel (5L) included
- Anti-legionella cycle
- External temperature range -25~45°C
- SG Ready
- Touch Screen color wired control included



TWMB5 9000 J

TWMB5 16000 J

Energy class



SMART GRID
Reading of the electricity network trend, guaranteed energy savings

EN 16147 certification from a third-party laboratory accredited by TUV Sud



| Model | | TWMB5 9000 J | | TWMB5 16000 J | |
|----------------------------|---|----------------|-------------------------------|---------------------|---------------|
| Nominal performance | Rated power | A7/W55 | kW | 8.12 | 13.60 |
| | Electrical absorption | | COP | 2.66 | 4.41 |
| | Coefficient of performance | | W/W | 3.05 | 3.08 |
| Seasonal data | COPDHW ¹ | | 3.045 | 2.49 | |
| | Test cycle profile ¹ | | L | XL | |
| | Energy efficiency (η _{wh}) ² | % | 121.8 | 99.5 | |
| | Energy Efficiency Class ² | | A+ | A | |
| Operating limits | Annual energy consumption ² | kWh/y | 842 | 1686 | |
| | Outdoor air temperature | °C | -25~45 | | |
| | Hot water T. adjustment range | | 25~70 | | |
| Refrigeration circuit data | Refrigerant ³ | type (GWP) | R290 (0.02) | | |
| | Quantity | kg | 1.0 | 1.4 | |
| | Control system | | Electronic expansion valve | | |
| Hydraulic data | Compressor | type | Rotary - DC Inverter | | |
| | Heat exchanger | Type | STAINLESS STEEL brazed plates | | |
| | | Water flow | m ³ /h | 1.57 | 2.75 |
| | | Pressure drops | kPa | 40 | 60 |
| | Circulation pump | | Included | | |
| | Water connections | Type | Threaded | | |
| | | Dimensions | inches | 1" (DN25) | 1 1/4" (DN32) |
| Operating pressure Min/Max | | bar | 0.5/3.0 | | |
| Expansion vessel | Volume | L | 5 | | |
| Electrical data | Power supply | Ph/V/Hz | 1ph-230V-50Hz | | |
| | Max. current | A | 13.70 | 27.00 | |
| | Power cable (recommended) | type | 3x4 mm ² | 3x6 mm ² | |
| Product specifications | Fan | Type | DC Inverter x 1 | | |
| | | Air flow | m ³ /h | 4300 | 8000 |
| | Sound power level | | dB(A) | 64 | 69 |
| | Dimensions | LxDxH | mm | 1115x415x900 | 1115x415x1320 |
| Controls | Net | Weight | kg | 95 | 140 |
| | Remote control colour touch screen | | | Included | |
| | WiFi module | | | Integrated | |

1. Test according to EN16147; air 7° C, inlet water 10° C. 2. Directive 2009/125/CE - ERP EU n. 814/2013 (TUV SUD certification for all models).

3. La perdita di refrigerante contribuisce al cambiamento climatico. In caso di rilascio nell'atmosfera, i refrigeranti con un potenziale di riscaldamento globale (GWP) più basso contribuiscono in misura minore al riscaldamento globale rispetto a quelli con un GWP più elevato. Questo apparecchio contiene un fluido refrigerante con un GWP di 0,02. Se 1 kg di questo fluido refrigerante fosse rilasciato nell'atmosfera, quindi, l'impatto sul riscaldamento globale sarebbe 50 volte inferiore rispetto a 1 kg di CO₂, per un periodo di 100 anni. In nessun caso l'utente deve cercare di intervenire sul circuito refrigerante o di disassemblare il prodotto. In caso di necessità occorre sempre rivolgersi a personale qualificato.

DHW production for a micro-apartment building

Description of the installation

The application typology exemplified in the figure below describes a system inside a micro-apartment in which the production of DHW is entrusted to the Termal Monobloc R290, connected to a 300/500L or more storage boiler, depending on the occupants. The Termal R290 Monobloc is able to accumulate DHW up to 70° C with the compressor alone, using a resistance in the boiler it is possible to further increase the temperature.

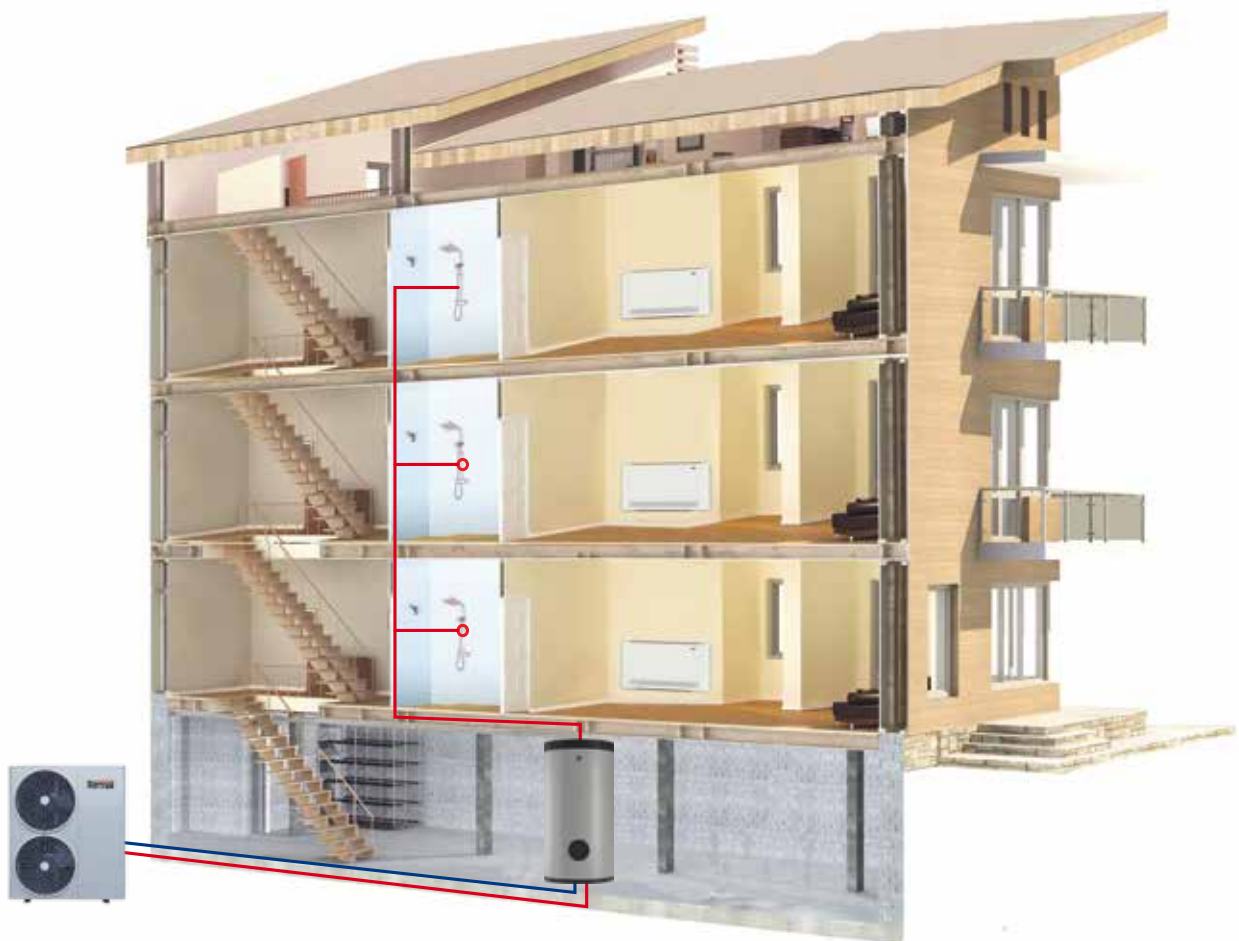

Calculation according to UNI TS 11300-2

 3
apartments

 300/500 L
total DHW requirements per day

 Up to 70°C
water temperature inside
the tank

 40°C
water supply
temperature to
utilities

HEAT PUMP HEATERS **ONSEN** FOR SWIMMING POOLS

GAS R32

QUICK INSTALLATION

RUSTPROOF ABS CASING



2 single-phase & 1 three-phase models



2 three-phase models



The pleasure of swimming in a pool in all seasons

Termal heat pump heaters can be used in small, medium, and large indoor as well as outdoor pools.

They are an effective solution for heating swimming pool water, even in late autumn or during sudden drops in temperature, **thus extending the bathing season**.

Equipped with a titanium heat exchanger and high-efficiency compressor, Termal swimming pool heat pumps guarantee absolute operational reliability, high energy performance and low operating consumption.

Titanium heat exchanger: a guarantee of safety and reliability

All **Termal heat pump heaters** are equipped with a titanium exchanger capable of heating any type of water, irrespective of its origin and the treatment used (chlorine treatment, salt sterilisation, bromine, ozone, etc.) and all systems with extensive disinfection requirements.

The titanium alloy provides maximum protection, guaranteed over time, against corrosion caused by chlorine.

Durable materials: ABS pump body

All units are **encased in a rust-free thermoformed ABS outer shell**.

This casing makes it possible to install all products in the open air, without the risk of deterioration caused by atmospheric agents or the need for special maintenance.

Heat pump heaters for swimming pools **ONSEN** in **R32**

INTEGRATED
Wi-Fi 

- New design, ABS plastic casing, rustproof
- Refrigerant gas R32
- 2 single-phase models from 12.50 to 15.60 kW;
1 three-phase model from 31.66 kW
- Titanium heat exchanger
- Operating air temperature -10°C~+43°C



single-phase
TCPHNB 1201 Z
TCPHNB 1501 Z

three-phase
TCPHSB 3101 Z



| Model | | TCPHNB 1201 Z | TCPHNB 1501 Z | TCPHSB 3101 Z |
|--|-------------------|---------------------|---------------|---------------|
| Estimated swimming pool volume | m ³ | 35-50 | 50-70 | 90-120 |
| Operating range | °C | -10~43 | -10~43 | -10~43 |
| Conditions - Air 26° C DB/24.3° C WB - Water 26° C in / 28° C out | | | | |
| Heating capacity | kW | 12.50~2.89 | 15.60~3.61 | 31.66~6.97 |
| Power consumption | kW | 1.82~0.216 | 2.25~0.27 | 4.61~0.523 |
| Current absorbed | A | 7.99~0.97 | 9.88~1.21 | 8.24~0.93 |
| COP | W/W | 13.38~6.87 | 13.37~6.93 | 13.33~6.87 |
| Conditions - Air 15° C DB/12° C WB - Water 26° C in / 28° C out | | | | |
| Heating capacity | kW | 9.37~2.17 | 12.48~2.88 | 23.63~5.35 |
| Power consumption | kW | 1.90~0.30 | 2.53~0.40 | 4.81~0.746 |
| Current absorbed | A | 8.34~1.34 | 11.11~1.79 | 8.60~1.33 |
| COP | W/W | 7.23~4.93 | 7.24~4.93 | 7.17~4.91 |
| Conditions - Air 35° C DB - Water 27° C in / 25° C out | | | | |
| Cooling capacity | kW | 5.00~2.80 | 6.8~4.20 | 15.76~5.94 |
| Power consumption | kW | 1.43~0.598 | 1.94~0.887 | 4.64~1.25 |
| Current absorbed | A | 6.28~2.68 | 8.52~3.98 | 8.29~2.23 |
| EER | W/W | 4.68~3.5 | 4.74~3.51 | 4.74~3.40 |
| Power supply | V/Ph/Hz | 220-240/1/50 | | 380-415V/3/50 |
| Max current absorbed | A | 16.40 | 17.70 | 11.6 |
| Water capacity | m ³ /h | 4 | 5.3 | 10.5 |
| Refrigerant ¹ | type (GWP) | R32 (675) | | R32 (675) |
| Quantity (tons CO2) | kg (t) | 0.55 (0.37) | | 0.75 (0.51) |
| Dimensions LxDxH | mm | 930x340x650 | 930x340x650 | 1220x440x850 |
| Net weight | kg | 43 | 45 | 108 |
| Sound pressure at 1 m | dB(A) | 40~48 | 41~50 | <51 |
| Compressor | type | Rotary | | |
| Evaporator | type | Finned copper pipes | | |
| Protection degree | | IPX4 | IPX4 | IPX4 |

1. Refrigerant leakage contributes to climate change. When released into the atmosphere, refrigerants with a lower global warming potential (GWP) contribute less to global warming than those with a higher GWP. This appliance contains a refrigerant with a GWP of 675. If 1 kg of this refrigerant fluid were released into the atmosphere, therefore, the impact on global warming would be 675 times less than 1 kg of CO₂, over a period of 100 years. Under no circumstances should the user try to intervene on the refrigerant circuit or disassemble the product. Always contact qualified personnel if necessary.

Silence

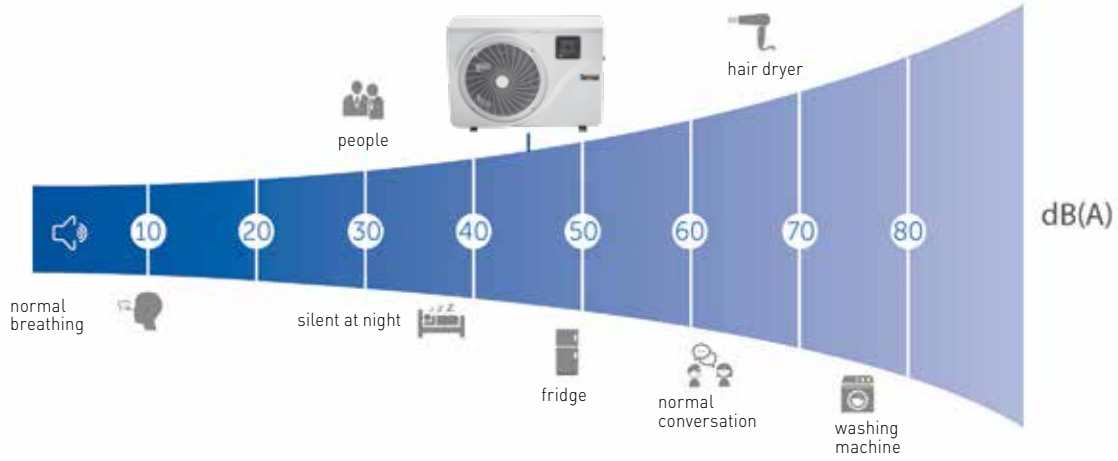

Applications

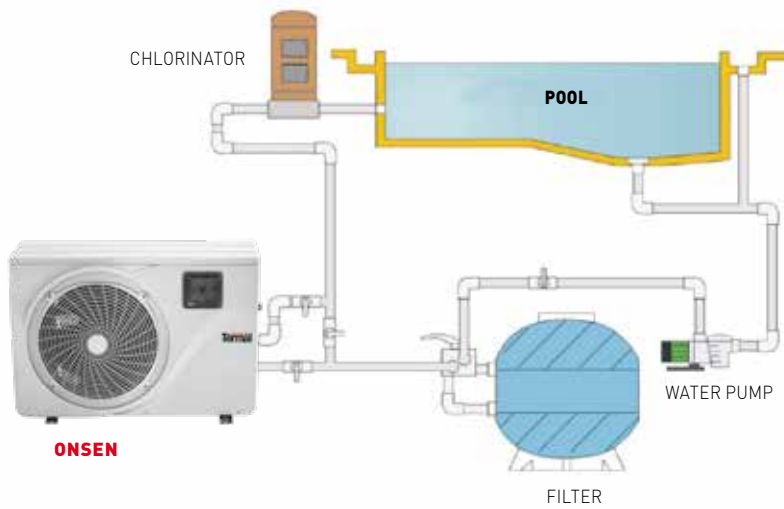
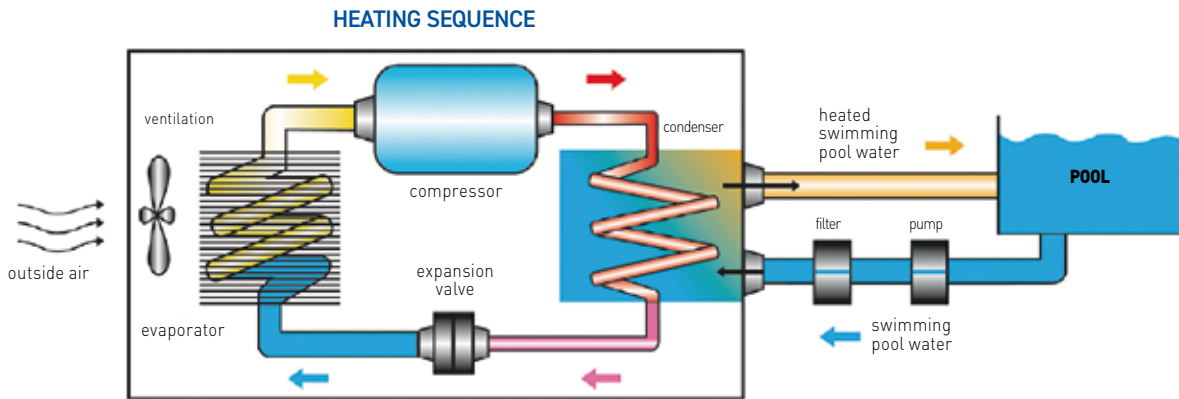

Heat pump heaters for swimming pools **ONSEN** in **R32**

INTEGRATED
Wi-Fi 

- New design, ABS plastic casing, rustproof
- Refrigerant gas R32
- 2 three-phase models from 40.30 to 45.65 kW;
- Titanium heat exchanger
- Operating air temperature -10°C~+43°C



three-phase
TCPVSB 4001 Z
TCPVSB 4601 Z

*** Distributor note**

The data shown may be subject to change. For updated information, please consult the latest version of the catalogue available on the website www.mitsubishi-termal.it.



| Model | | TCPVSB 4001 Z* | TCPVSB 4601 Z* |
|--|-------------------|---------------------|----------------|
| Estimated swimming pool volume | m ³ | 120~160 | 120~160 |
| Operating range | °C | -10~43 | -10~43 |
| Conditions - Air 26° C DB/24.3° C WB - Water 26° C in / 28° C out | | | |
| Heating capacity | kW | 40.3~8.79 | 45.65~8.79 |
| Power consumption | kW | 6.14~0.77 | 7.08~0.78 |
| COP | W/W | 11.47~6.56 | 11.27~6.44 |
| Conditions - Air 15° C DB/12° C WB - Water 26° C in / 28° C out | | | |
| Heating capacity | kW | 30.06~6.31 | 35.02~7.33 |
| Power consumption | kW | 6.44~0.939 | 7.40~1.10 |
| COP | W/W | 6.72~4.66 | 6.66~4.73 |
| Conditions - Air 35° C DB - Water 27° C in / 25° C out | | | |
| Cooling capacity | kW | 19.54~8.51 | 22.76~7.36 |
| Power consumption | kW | 5.76~1.76 | 6.82~1.56 |
| EER | | 4.84~3.39 | 4.72~3.33 |
| Power supply | V/Ph/Hz | 380-415V/3/50 | |
| Max current absorbed | A | 14.66 | 16.22 |
| Water capacity | m ³ /h | 14.5 | 15.1 |
| Refrigerant ¹ | type (GWP) | R32 (675) | |
| Quantity (tons CO2) | kg (t) | 2.7 (1.82) | 3.0 (2.03) |
| Dimensions LxDxH | mm | 659x732x913 | |
| Net weight | kg | 95 | 105 |
| Sound pressure at 1 m | dB(A) | 58 | 58 |
| Compressor | type | Rotary | |
| Evaporator | type | Finned copper pipes | |
| Protection degree | | IPX4 | IPX4 |

1. Refrigerant leakage contributes to climate change. When released into the atmosphere, refrigerants with a lower global warming potential (GWP) contribute less to global warming than those with a higher GWP. This appliance contains a refrigerant with a GWP of 675. If 1 kg of this refrigerant fluid were released into the atmosphere, therefore, the impact on global warming would be 675 times less than 1 kg of CO2, over a period of 100 years. Under no circumstances should the user try to intervene on the refrigerant circuit or disassemble the product. Always contact qualified personnel if necessary.

Silence

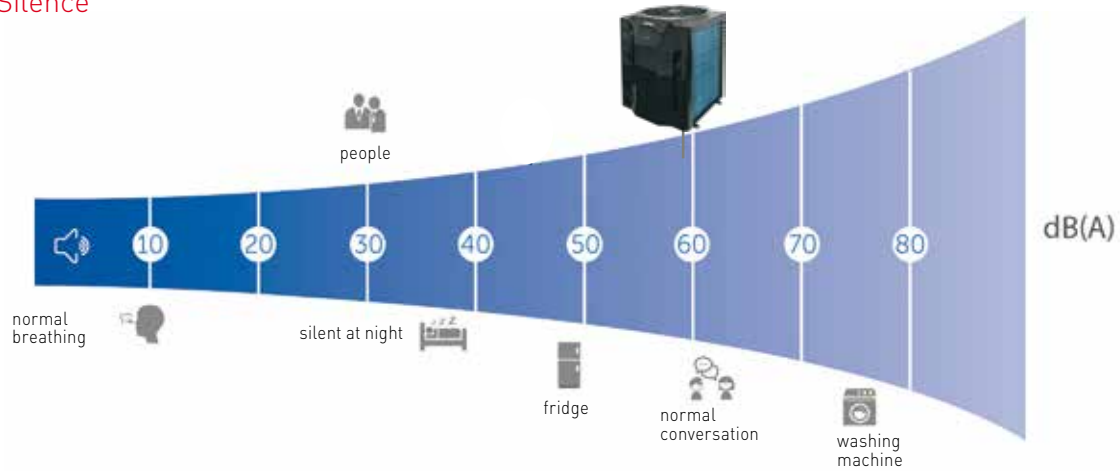

Applications

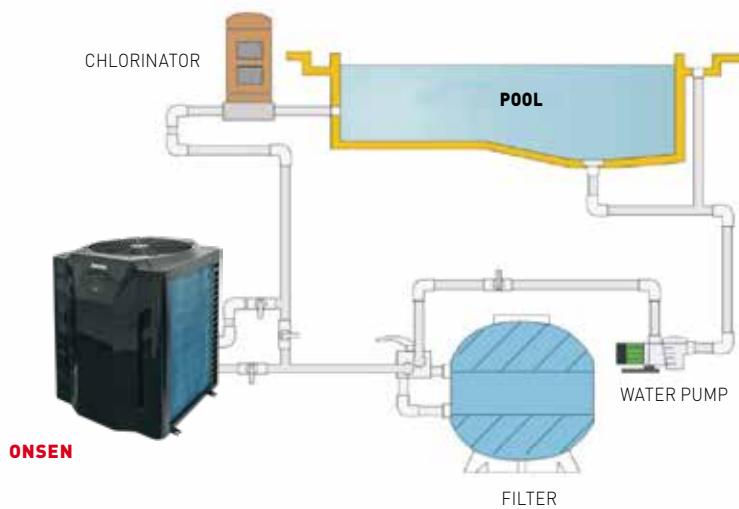
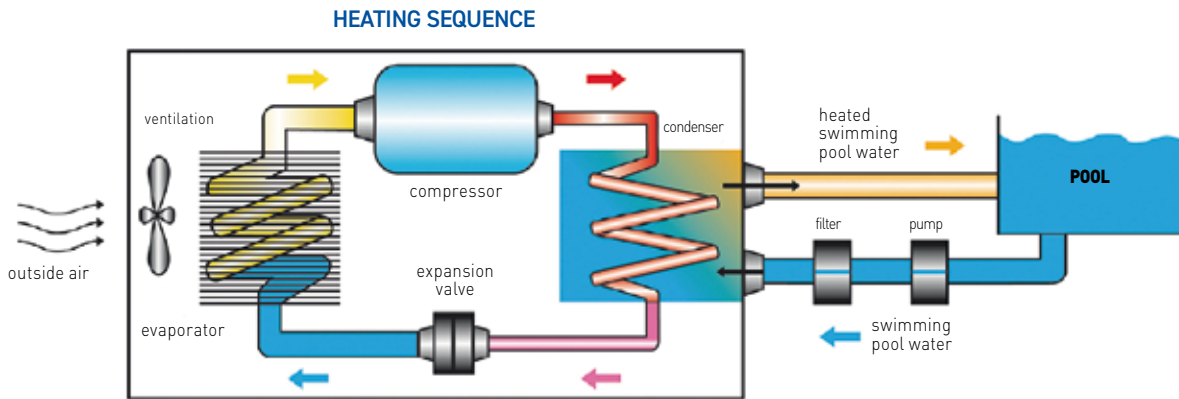

Only

**AIR CONDITIONER
WITHOUT OUTDOOR UNIT**

**R32 REFRIGERANT GAS
(GWP 675)**

**COOL IN THE SUMMER
WARM IN THE WINTER
DESIGN ALL YEAR LONG**



Only in



“Onlyin”, the heat pump without outdoor unit combines the evaporating and condensing part in a single unit, normally divided into traditional splits composed by two units

A+/A
TTWIS 310 Z



The advantages

Ideal for historical buildings

Since it has no outdoor unit, its installation does not compromise the aesthetics of the building's façade. Its modern, essential design with a depth of only 17 cm adapts to all types of interiors, for air conditioning "without architectural barriers."

Low consumption

DC Inverter technology makes "Only in" consumption very low. Once the desired temperature has been reached, the units run at minimum power, reducing air outlet speed in the environment, thus significantly reducing electrical consumption.

Less Maintenance

Practically no maintenance is required since the cooling circuit is "sealed" and therefore free of any refrigerant pipes.

Quiet

Thanks to the power used, the internal layout and skilful use of soundproofing materials, "Only in" offers exceptional levels of quiet: it is difficult to tell it apart from a normal wall split unit.

Easy to install

Without an outdoor unit, it can be easily installed on any perimeter wall, even without the presence of a qualified refrigeration installer. Simply drill two 16.2 cm diameter holes in the wall. No need to then lay any pipes which normally connect the indoor and outdoor units.

Remote and on-board control

"Only in" is equipped with a practical, functional remote control. A convenient control panel is also present on-board the machine, from where all settings can be made including the "LOCK" function which locks the keyboard. The "heating" function can also be deactivated from the control panel. "Only in" therefore can operate only in "cold" and can be installed without a condensate drain pipe.



Retractable outer grilles

The tilting outer grilles open only when the unit is running. This guarantees better indoor comfort as it reduces the entry of dust, noise and pollution and requires less maintenance and even less visibility outside. The outer grilles can be painted with the same colour as the façade to almost completely hide its installation.



AIR CONDITIONER WITHOUT OUTDOOR UNIT



Technical installation information

- A** Holes for M8 plugs
- B** Area for electrical connection
- C** Holes for Ø160 mm air ducting
- D** Ø14 mm condensate drain

Assembly template, support bracket, pipes for holes and outer grilles are contained inside packaging.

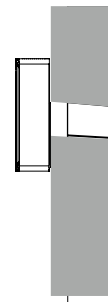
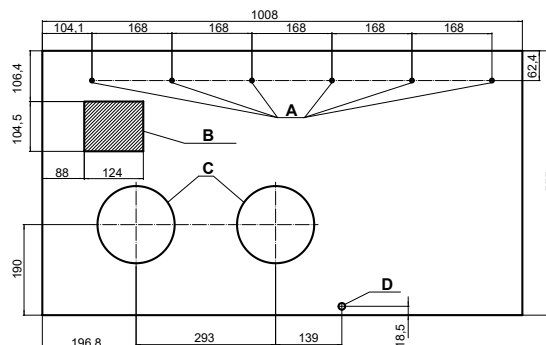

New wall control T-DTW-ST-Modbus

- Cable included (8 m)
- Modulating speed
- Touch Screen Interface
- Built-in Modbus port



| Model | | | TTWIS 310 Z |
|---|------------|-------------------|--|
| Type | | | Monobloc double duct - DC-Inverter heat pump |
| Control | | | Panel + Remote control |
| Rated capacity (T=+35°C) | Cooling | kW | 2.33 |
| Rated capacity (Dual-Power function) | | kW | 3.10 |
| Rated absorbed power | | kW | 0.72 |
| Rated energy efficiency coefficient | | EER1 | 3.25 |
| Seasonal energy efficiency class | | 626/20112 | A+ |
| Dehumidifying capacity | Heating | L/h | 0.9 |
| Rated capacity (T=+7°C) | | kW | 2.31 |
| Rated capacity (Dual-Power function) | | kW | 3.05 |
| Rated absorbed power | | kW | 0.71 |
| Rated energy efficiency coefficient | | COP1 | 3.28 |
| Seasonal energy efficiency class | 626/20112 | A | |
| Electrical data | | | |
| Power | Ph-V-Hz | | 1Ph - 220/240V - 50Hz |
| MAX absorbed current | A | | 4.60 |
| Refrigerant circuit | | | |
| Refrigerant ³ | Type (GWP) | | R32 (675) |
| Quantity (tons CO ₂) | kg (t) | | 0.50 (0.338) |
| Product specifications | | | |
| Dimensions | LxDxH | mm | 1030x555x170 |
| Net weight | | kg | 41 |
| Sound power level | | dB(A) | 58 |
| Sound pressure level | Hi-Lo | dB(A) | 41-27 |
| | Hi | m ³ /h | 400/480 |
| Treated air volume (indoor/outdoor) | Mi | m ³ /h | 320/390 |
| | Lo | m ³ /h | 270/340 |
| | | | |
| Operating limit (indoor environment) | Cooling | °C (DB) | 18~35 |
| | Heating | °C (DB) | 5~27 |
| Operating limit (outdoor environment) | Cooling | °C (DB) | -5~43 |
| | Heating | °C (DB) | -10~24 |
| Installation | | | |
| Wall hole diameter | mm | | 162 |
| Wall hole distance | mm | | 293 |
| Optional parts | | | |
| Decorative foot kit | | | TTWIS 2200 CINF |
| Smart Touch + ModBus wall control panel | | | T-DTW-ST-Modbus |

1. Value measured according to harmonised standard EN14511. 2. Delegated Regulation UE N.626/2011 with regard to energy labelling indicating the energy consumption of air conditioners. 3. Refrigerant leakage contributes to climate change. When released into the atmosphere, refrigerants with a lower global warming potential (GWP) contribute less to global warming than those with a higher GWP. This appliance contains a refrigerant with a GWP of 675. If 1 kg of this refrigerant fluid were released into the atmosphere, therefore, the impact on global warming would be 675 times higher than 1 kg of CO₂, over a period of 100 years. Under no circumstances should the user try to intervene on the refrigerant circuit or disassemble the product. Always contact qualified personnel if necessary.

TOTAL HEAT EXCHANGER

ENERGY RECOVERY
DURING HEAT EXCHANGE
INSIDE THE ROOMS

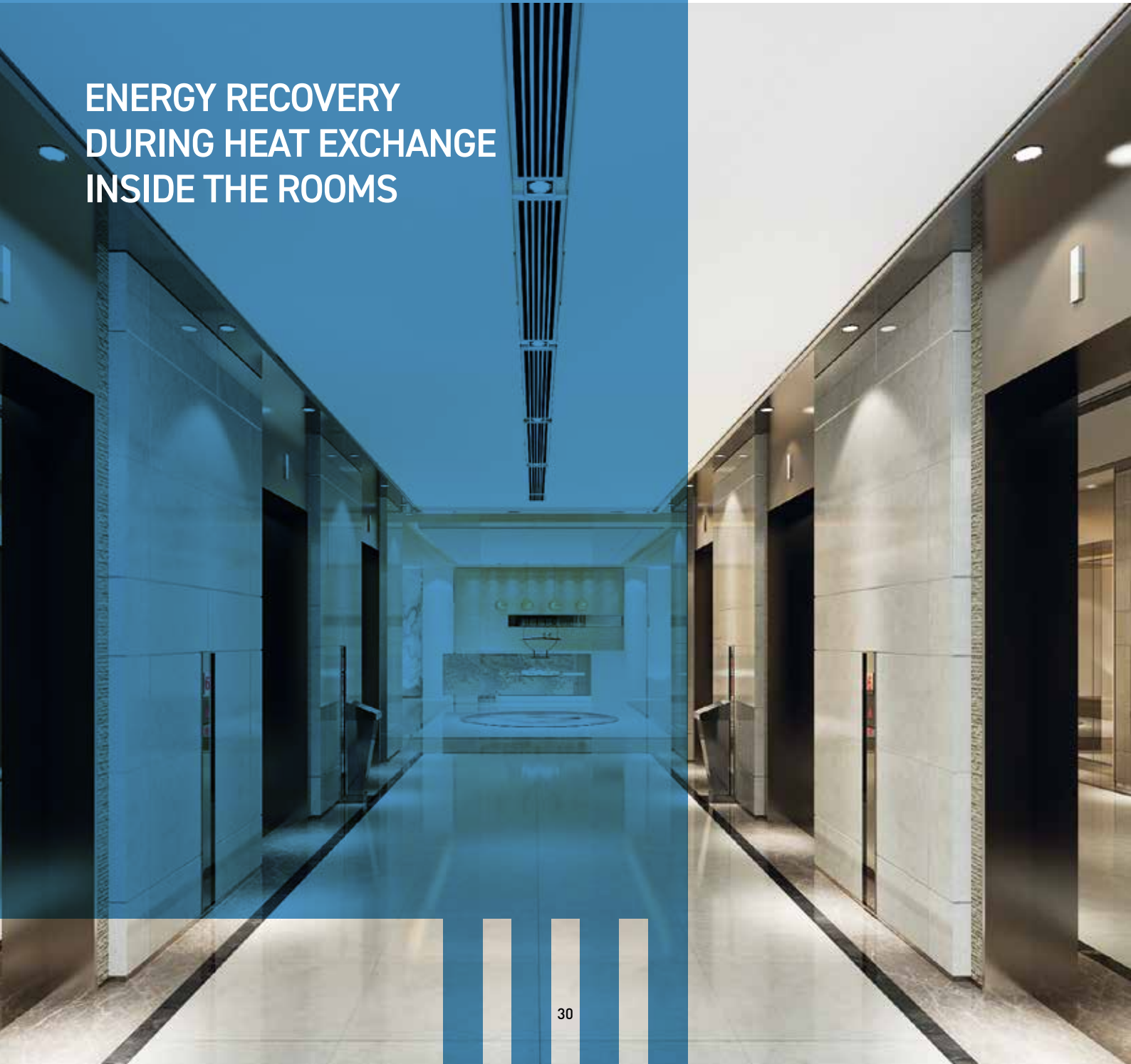

TOTAL HEAT EXCHANGER



ETIN 805~2005

- 4 capacities: 800~2000 m³/h
- DC Inverter fan.
- Mandatory wire controller

Ventilation units with heat recovery are suited for use in bars, restaurants, offices, gyms, changing rooms where air needs to be exchanged during hours of operation.

The unit consists of two centrifugal fans: one introduces clean air filtered from outside and the other one expels the stale air from the inside. The two air flows go through a blade heat exchanger, in which part of the heat is recovered.

Depending on the season, the indoor air heats or cools the outdoor air, which is introduced without coming into contact with it.

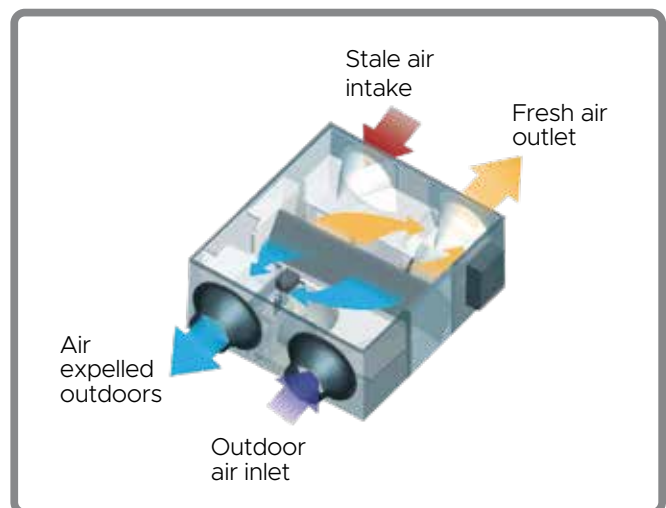

| Model | | ETIN 805 | | ETIN 1005 | | ETIN 1505 | | ETIN 2005 | |
|----------------------------------|----------|-------------------|---------------|-----------|---------------|-----------|---------------|-----------|---------------|
| Exchange efficiency ¹ | Enthalpy | % | 72.3 | | 76.0 | | 69.4 | | 74.7 |
| | Thermal | % | 78.7 | | 82.8 | | 75.5 | | 77.2 |
| Electrical data | | | | | | | | | |
| Power supply | | Ph-V-Hz | 1-220~240-50 | | | | | | |
| Power absorption | | W | 320 | | 380 | | 680 | | 950 |
| Rated absorbed current | | A | 2.40 | | 2.90 | | 3.80 | | 5.70 |
| Product specifications | | | | | | | | | |
| External dimensions | DxLxH | mm | 1311x1286x390 | | 1311x1526x390 | | 1740x1425x615 | | 1811x1625x685 |
| Net weight | | Kg | 80 | | 90 | | 181.5 | | 208.5 |
| Sound power level | Hi | dB(A) | 55 | | 54 | | 69 | | 70 |
| Treated air volume | | m ³ /h | 800 | | 1000 | | 1500 | | 2000 |
| Fan static pressure | Hi | Pa | 140 | | 160 | | 180 | | 200 |
| Ducting flange | | mm | ø244 | | ø244 | | ø346x326 | | ø346x326 |
| Condensate drain pipe | | | Not required | | | Necessary | | | |
| Operating range (max UR 80%) | | °C | -7~43 | | | | | | |
| Degree of protection | | | IPX2 | | | | | | |
| Accessories | | | | | | | | | |
| Wired control (not included) | | | DHW EH5 | | | | | | |
| Optional parts | | | | | | | | | |
| Group control | | | DHW-16-XRV-P | | | | | | |

Reference legislation: EU Ecodesign Directive 1253/2014 for non-residential ventilation units (NRVU) and residential ventilation (RVU).
1. Values related to the high speed of the 3 levels settable by wired remote control.

Due to the continuous technological evolution of our products, we reserve the right to vary the technical specifications within this catalogue at any time and without prior notice. The hydraulic diagrams shown are only examples and do not replace the system design.





CATALOGUE PRODUCTS 2025

**HOT WATER R290 | MONOBLOC R290 | HEATERS ONSEN
ONLY IN | TOTAL HEAT EXCHANGER**



TERMAL SALES S.r.l.

Via della Salute, 14
40132 Bologna - Italy
Tel. +39 051 41 33 111
Fax +39 051 41 33 112

www.termal.it